

SPECIFICATION

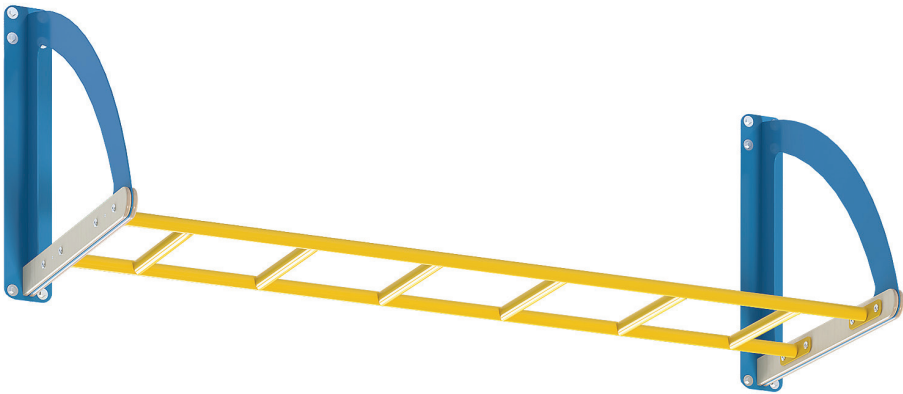

«Turbo» horizontal ladder

Article: e1184-4

DISTRIBUTED
BY PLAYLEARN

PLAYLEARN
Know.Grow.Smile.

1. GENERAL DESCRIPTION

«Turbo» horizontal ladder is simple and reliable sports equipment for exercises. A variety of classes on such simulators develop general motility and contribute to the formation of spatial representation. Ladders can be combined and lined up in an obstacle course, placed near a climbing wall or Wall bars.

Any gym can be supplemented with horizontal ladder. You add a maximum of functionality by using a minimum of space.

2. SPECIFICATIONS

Material: steel pipe, steel bracket.

Coating type: powder paint.

Overall dimensions, mm:

Bracket - 120×720×700.

Handrail - 1950×520×210.

Dimensions in packed view , mm:

Bracket – 746x766x186.

Ladder - 1996x566x256.

Total weight, kg: 40.

Acceptable weight load, kg: 60.

Component parts: bracket - 2 pcs., handrail - 1 pc., set of fasteners – 1 pc. (see point 7).

Age: 3+.

3. STORAGE

Store in dry indoor areas in compliance with temperatures from + 5 °C to + 30 °C and a permissible humidity of 30-70%, at a distance of at least 1 m from heating appliances and direct sunlight.

4. RECOMMENDATIONS

- It is intended for indoor use only.
- It is necessary to check reliability of all fastenings before each class.
- Check the parts for signs of wear. Do not use damaged equipment.
- The room should be spacious enough so that the child can freely use the equipment in a comfortable position.
- Use at a safe distance from walls, windows, stairs, other objects and furniture.
- Do not place other gaming equipment under the ladder.
- We recommend using the mats in the exercise area.
- Use on a flat, stable surface.
- All exercises must be performed in the presence of a competent adult. It is important to control and adjust, if necessary, the child's posture and balance on the roller board during exercise.

5. CARE

- Store the product only in dry, covered, heated rooms until installation.
- Clean and inspect the equipment regularly to allow you to see possible damage in time and prevent malfunction or corrosion. Keep it clean, translations should be clean, dry, non-slippery and not rough.
- Use a soft, damp cloth for cleaning. Do not use metal brushes or abrasive cleaners.
- Check the tightness of the fasteners and threaded connections at least once a month (periodicity of inspection depends on the intensity of use).

6. ATTENTION! DISCLAIMER

- Be sure to unpack the product. Packing can be dangerous for children!
- Please check the equipment for damage that may occur during delivery.



SPECIFICATION

- Do not place the device near central heating radiators or heaters, or in direct sunlight, near air conditioners.

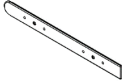

- Warning! The equipment has age restrictions - not intended for children under 3 years.
- All exercises should be performed in the presence of an adult.
- Pay attention to weight restrictions: if the design is not intended to weigh more than 60 kg, do not exceed the maximum allowable load.
- Do not fasten a product to brittle and uneven surfaces.
- Do not use until proper installation has been completed.
- After installation, make sure that the fasteners are securely fastened.
- If you see or suspect a malfunction, do not use the equipment until qualified personnel have checked and solved the problem.

7. MOUNTING

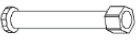
| Component parts of the mounting kit of brackets | | | |
|---|------------------------------|---|---------------|
| Nº | Component name | View | Quantity, pcs |
| 1 | Frame |  | 2 |
| 2 | Overlay |  | 4 |
| 3 | Ericsson nut M6x10 |  | 4 |
| 4 | Screw M6x20 |  | 4 |
| 5 | Anchor 12x120 |  | 12 |

It is recommended mounting to a retaining (load-bearing) wall or a wall made of concrete, stone, granite, solid blocks or solid brick.

Tools needed for installation:

- perforator;
- screwdriver;
- a set of hexagon keys;
- pencil and ruler.

Make a mark on the wall for anchors.

Drill holes with a perforator, clean them from dust. Install an anchor dowel 12x120 in each hole.

Fasten the plywood overlays to the lower part of the bracket frame with M6x20 screws and Ericsson nuts (see Pic. 1).



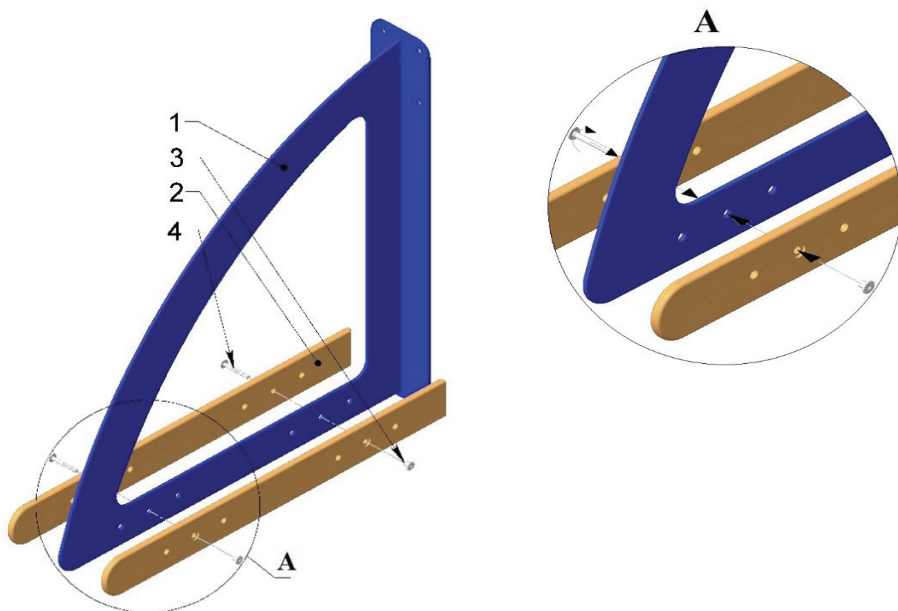

Fasten the brackets to the wall with anchor screws (see Pic. 2).

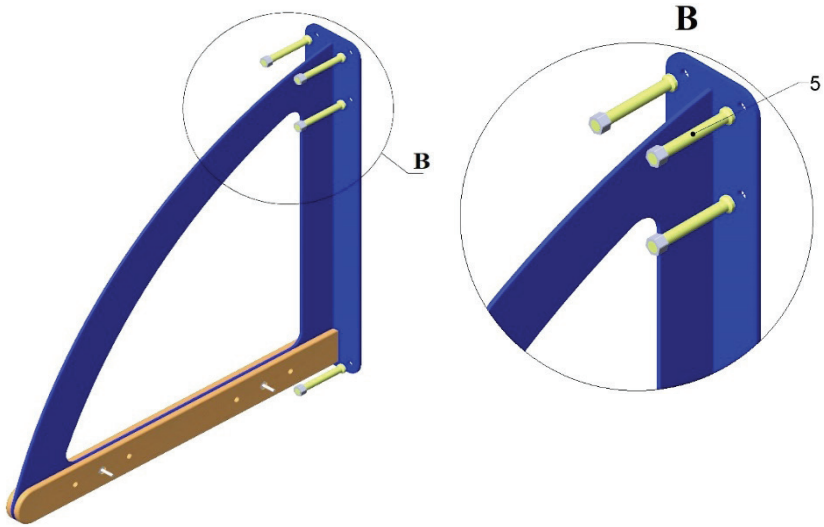

Pic.1. Mounting scheme of bracket.

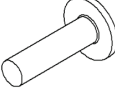

Pic.2. Mounting scheme of bracket.

| Component parts of the mounting kit of ladder | | | |
|--|--------------------|---|---------------|
| Nº | Component name | View | Quantity, pcs |
| 1 | Bracket |  | 2 |
| 2 | Handrail |  | 1 |
| 3 | Screw M8x30 |  | 8 |
| 4 | Ericsson nut M8x16 |  | 8 |

Connect the handrail to the brackets with screws M8x30 and Ericsson nuts (see Pic. 3).

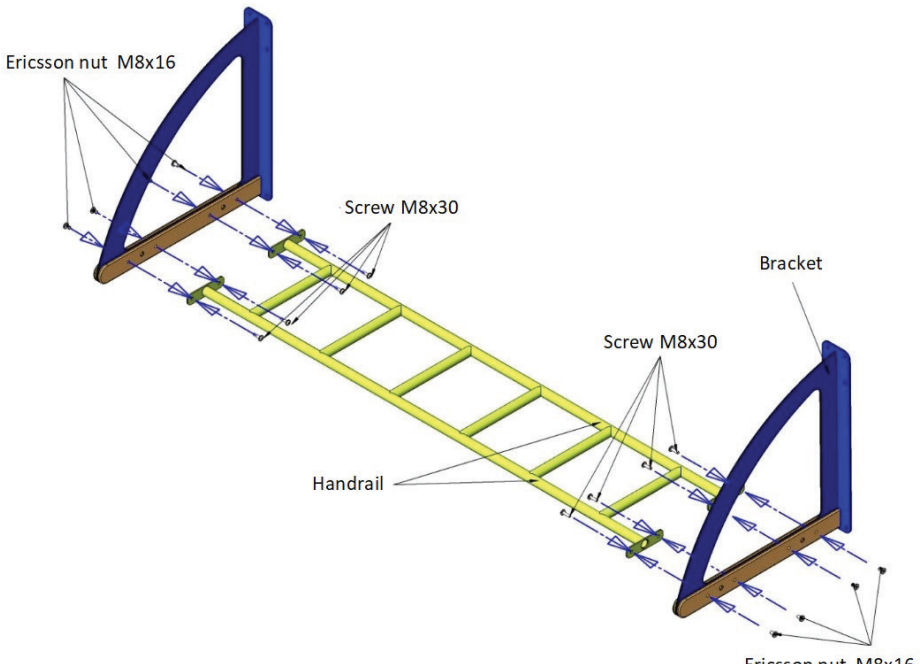

Pic.3. Connection scheme of handrail to brackets.

Customer support and assistance in the U.S.A.:



Web-site: www.playlearn.com

E-mail: support@playlearn.com
